

SP04(R)

Manual

Release management

This manual is applicable to:

- PCB SPO4 Rev00

©2013 This document, or any information contained herein, may not be copied or distributed, in whole or in parts, in whatever form, without the explicit written approval of the original author. The making of copies and prints by users of the DS32 module for their own use is allowed.

Contents

1	SP04.....	4
1.1	Introduction	4
1.2	Versions.....	4
1.3	Connections and functions.....	5
2	Assembly.....	6
2.1	Requirements.....	6
2.2	Assembling the module.....	6
3	Connecting.....	8
3.1	Power supply and heat	8
3.2	Connecting the servo's to the SP04	9
3.3	Connecting the SP04 to the OC32.....	10
4	To conclude.....	12

1 SP04

1.1 Introduction

The OC32 has the ability to control up to 32 servo motors. Usually, a servo motor has to be energized by a DC power supply between 4,5V and 6V. When in operation. A servo can use a substantial amount of energy. Therefore it would be unwise, if not impossible, to have the OC32 deliver this power from the internal 5V. For that reason, in the manual of the OC32, it is advised to provide a stabilized power supply to the servo's separately.

The SP04 is a compact module meant to provide 4 separate servo motors with the right power voltage and to connect them easily with i.a. the OC32. The SP04 is powered by a not necessarily stabilized DC voltage of 7V minimum.

To connect more than four servo's, additional SP04 modules are required.

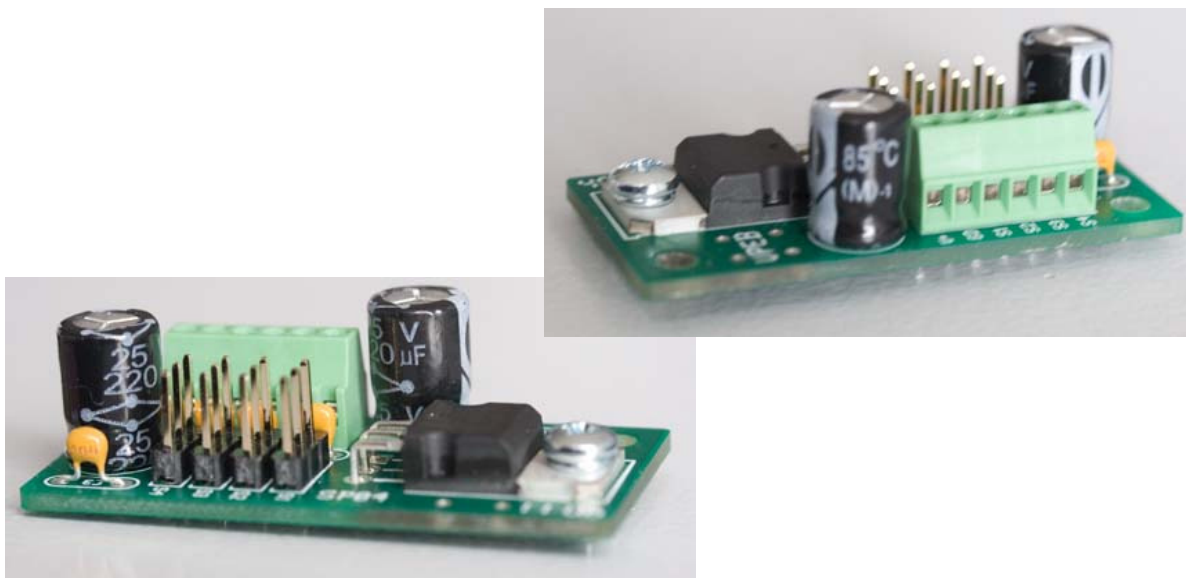

Fig 1: The SP04

1.2 Versions

The SP04 is an enhanced version of its predecessor, the SP4. The main difference is that on the SP04 decoupling capacitors have been mounted to suppress the interference signals on the signal wires between the OC32 and the SP04. This allows the SP04 to be used on a larger distance from the OC32.

The SP04 exists in two versions: the SP04 and the SP04R. The R-version has four extra "pull-up" resistors between the signal lead of the servo and the +5V. Mainly the cheaper servo's suffer from power-up problems. As soon as power is provided, the servo turns a little bit spontaneously. This unwanted effect is contained in the electronics of the servo itself not in the controlling. It is observed¹ that this spurious effect with many servo's can be diminished by rising the voltage on the control lead to +5V simultaneously with powering the servo. This can be achieved by inserting a pull-up resistor between the signal lead and the +5V. The SP04R has them and the SP04 does not. With the assembly kit SP04R you can choose to mount the resistors. With the assembled version one has to select the SP04R or the SP04. Afterwards mounting or removing the resistors is tedious.

¹ Thanks to Daan Neijenhuis (HCC!m)

1.3 Connections and functions

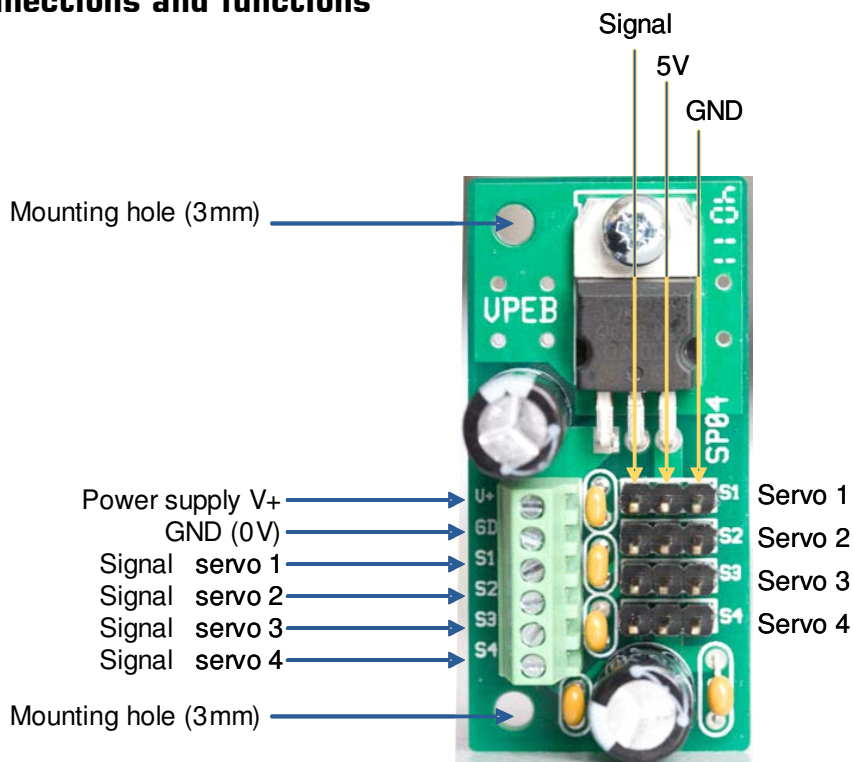

Fig 2: SP04 overview connections and functions

On the SP04 the following connections and functions are to be found:

- 4 Pin-headers to connect 4 servo's;
- A 6-way screw terminal to connect the power supply and the signals of the OC32;
- 2 Mounting holes.

2 Assembly

This chapter is applicable only if you have bought an assembly kit. If you have a readily assembled version you can proceed at chapter 3.

2.1 Requirements

Next to the SPO4(R) assembly kit and this manual you need:

- A soldering iron for electronics. Because the print itself also functions as cooling device at some soldering points a little more heat has to be applied to make the solder flow. A standard 15Watt soldering iron might not be sufficient. A soldering station will do in almost any case. Otherwise a 25Watt soldering iron will do the job. Use a long-life solder tip, especially if you use silver containing solder;
- Desoldering pump or desoldering braid (in case of emergency);
- Electronics quality solder, preferably lead free, with resin, 0,8mm or thinner;
- A small side-cutter for electronics or model construction;
- Small sized pliers;
- A screwdriver PZ1.

Be careful! to **NEVER** use S39 or similar fluid to solder. These chemicals creep into the PCB, disturb the operation and destroy the PCB from the inside, even while not in use. Specific solder fluids for electronic work can be purchased at the specialty store, however in essence these extra means are not required using normal solder with resin core.

2.2 Assembling the module

Identify the component side and the solder side of the print. The component side has the white print indicating the position of the components.

To make live easy, the following order is advised to be adhered to!

- Take the L7805 stabilizer and bend the leads with the pliers by 90 degrees, just at the position where the "wide" part of the leads go into the narrower part. Bend the leads in the direction of the metal back;
- Mount the L7805 at the place indicated with IC1. If the leads are bent correctly, the mounting hole of the IC corresponds exactly with the hole in the print. Take care that the metal back of the IC is layed flat on the PCB for cooling purposes and solder the leads. Cut the excessive length of the leads at the solder side;
- Solder the four 3-pole headers on the places S1 .. S4. **PAY ATTENTION!** If you are putting together an SPO4R (with pull-up resistors) solder of each header **ONLY** the pin closest to the edge of the print. Leave the other two for now. If you assemble the SPO4 (without pull-up resistors) all pins of the header can be soldered;
- Building an SPO4R put the pull-up resistors each in between the 2 pins of the headers which are not soldered yet. The resistors are SMD type and fit tightly in between the pins. Put the resistors with the white side on the PCB. The black side with imprint stays visible. Solder the remaining pins of the headers. The result should look like fig. 3;
- Fit the 6-pole screw terminal at the place next to text "V+..S4". The openings for the wires should point to the edge of the PCB;

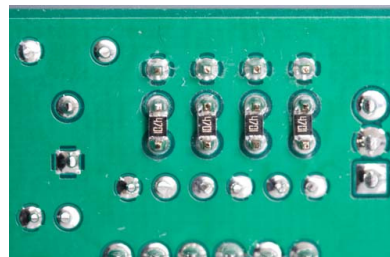

Fig 3: SMD pull-up resistors

- Mount the 100nF capacitor (imprint 104, spacing 5,08 mm) at location C3. Cut the excessive length of the leads at the soldering side;
- Mount the four 10nF capacitors (imprint 103, spacing 2,54mm) on the respective places. There is no component number on the print but it should be clear where to mount them. Cut the excessive length of the leads at the soldering side;
- Solder the two 220 μ F capacitors at locations C1 and C2. Be aware of the polarity! The longest lead (+) goes into the hole with the circular island and the shortest one (-) into the hole with the square island. Cut the excessive length of the leads at the soldering side;
- Secure the L7805 into position with the provided screw and nut. Insert the screw at the component side into the mounting hole of the IC and place the nut at the solder side. Hold the nut with pliers or other suitable tool and tighten the screw not overly.

Congratulations, your SP04 is ready!

3 Connecting

3.1 Power supply and heat

The SP04 provides a current of 1,5A maximum to in total 4 servo's. The SP04 is current limited.

The difference of the provided voltage and the 5V required for the servo's is converted into heat. The higher the voltage of the power supply you provide, the more energy is wasted and the hotter the SP04 gets. In most cases servo's use current for a very short period of time only. When the servo is moving a lot or needs energy to keep its position the current consumption and the dissipation increase. For this reason keep the provided power voltage as low as practically possible (but at 7V minimum) to minimize heat development.

The SP04 has an almost full copper layer at the back to spread and dissipate the excessive warmth. In most cases this will do. Take care that the back of the print can get rid of the warmth. Do not mount it flat on a surface but use spacers!

The supply voltage for the servo's, being the voltage you provide the SP04 with to generate 5V, can be the same power voltage you provide to the OC32, but a separate power supply can be used also. In the latter case the GND (0V) of both power supplies have to be connected.



BE CAREFUL: applying an alternating current or incorrectly polarized direct current to the SP04 will inevitably cause damage to the SP04 and possibly to the OC32 and the servo motors as-well!!

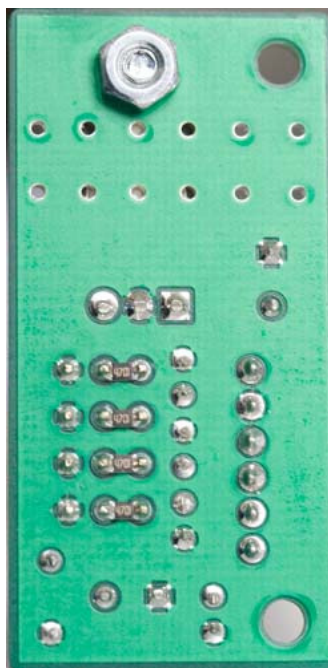

Fig 4: SP04, back is almost completely copper to dissipate the heat

3.2 Connecting the servo's to the SP04

A servo motor normally has a 3-pole connector. Most cases the pin in the middle is the plus (4,5 .. 6V) and the right most pin is the GND/OV. The left most pin is the signal lead directing the servo to go into the right position. **ATTENTION:** no guaranty that this pertains to all servo's so if unsure, refer to the documentation of the manufacturer!

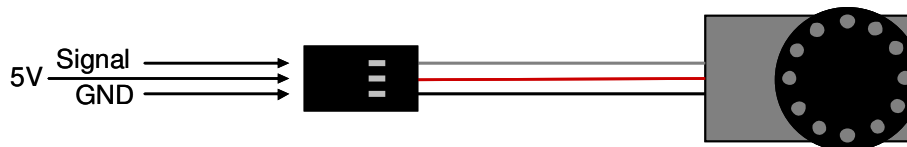

Fig 5: Connections servo

On the SP04 there are four 3-pole headers with the text S1 .. S4. Put the 3-pole connector of the servo on one of the pin-headers. The signal lead has to be at the side of the green screw terminal. Rest assured, if reversed nothing is damaged, only the servo does not work at all. Just turn the connector the other way.

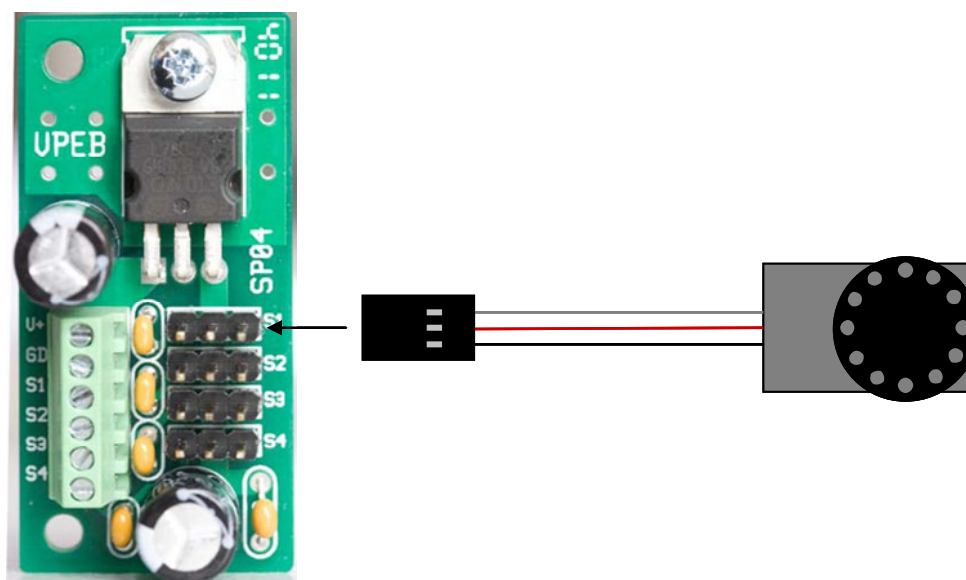

Fig 6: Connecting the servo to the SP04

3.3 Connecting the SP04 to the OC32

The SP04 is connected with 6 wires maximum. One GND/OV, one positive power voltage and four signal wires, one for each servo. The signal wires can have any diameter (0,14 square mm will do). For the power and the GND you need slightly thicker wire (0,22 mm² or even better 0,5 mm² will be good) especially on larger distances.

The GND is connected to the same GND to which the OC32 is connected. The power voltage can be obtained from the Vp of the OC32 or from a separate power supply. The max 4 signal wires are connected to four outputs of the OC32. Of course these outputs have to be configured to control servo's. Electrically the output has to be a 5V output with resistor array (preferably 220Ω). It is not required to use four consecutive outputs. They only have to be configured correctly and have the resistor array in place.

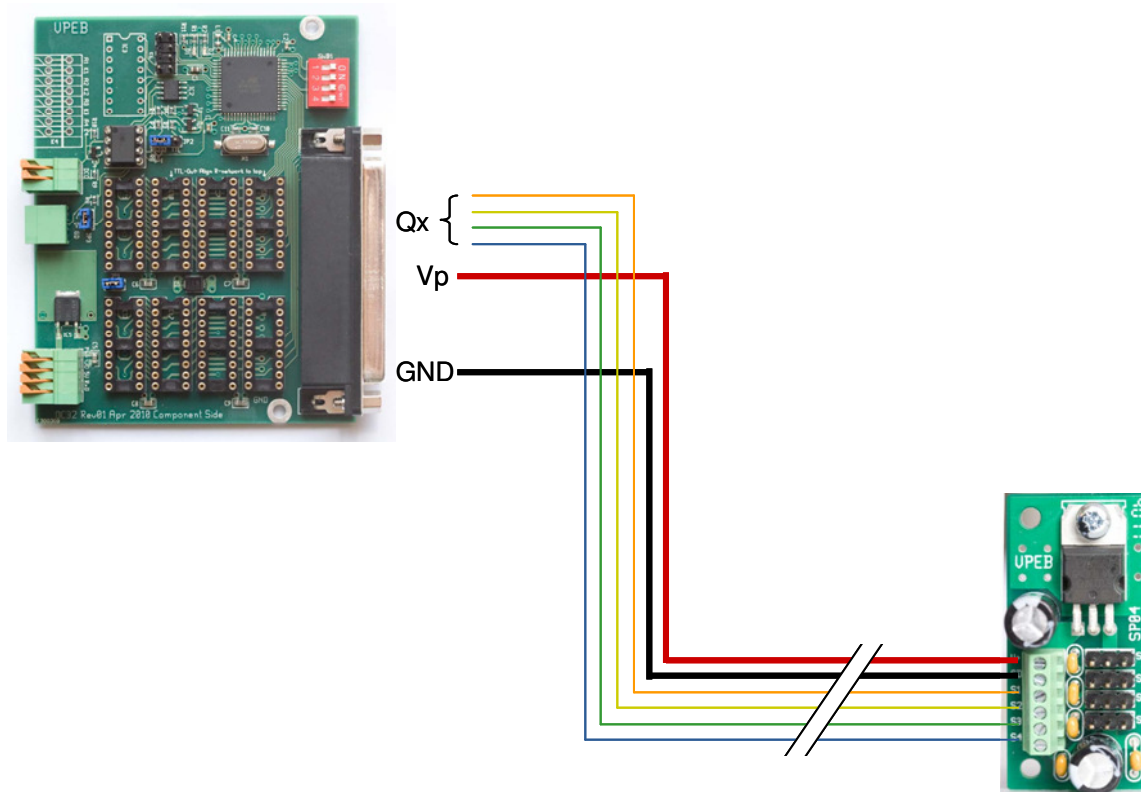

Fig 7: Connecting the SP04 to the OC32 and power supply

It is highly recommended to connect the GND and preferably also the power at the (physical) location where the signal for the servo is generated, using the OC32 thus at the location of the OC32 (thus according to picture 7 above). Twist or bundle all wires to the SP04 loosely together. This prevents induction of interference. Some types of servo are susceptible to this.

Be aware: it is advised **NOT** to obtain the power supply from another physical location (and hence not according to fig 8).

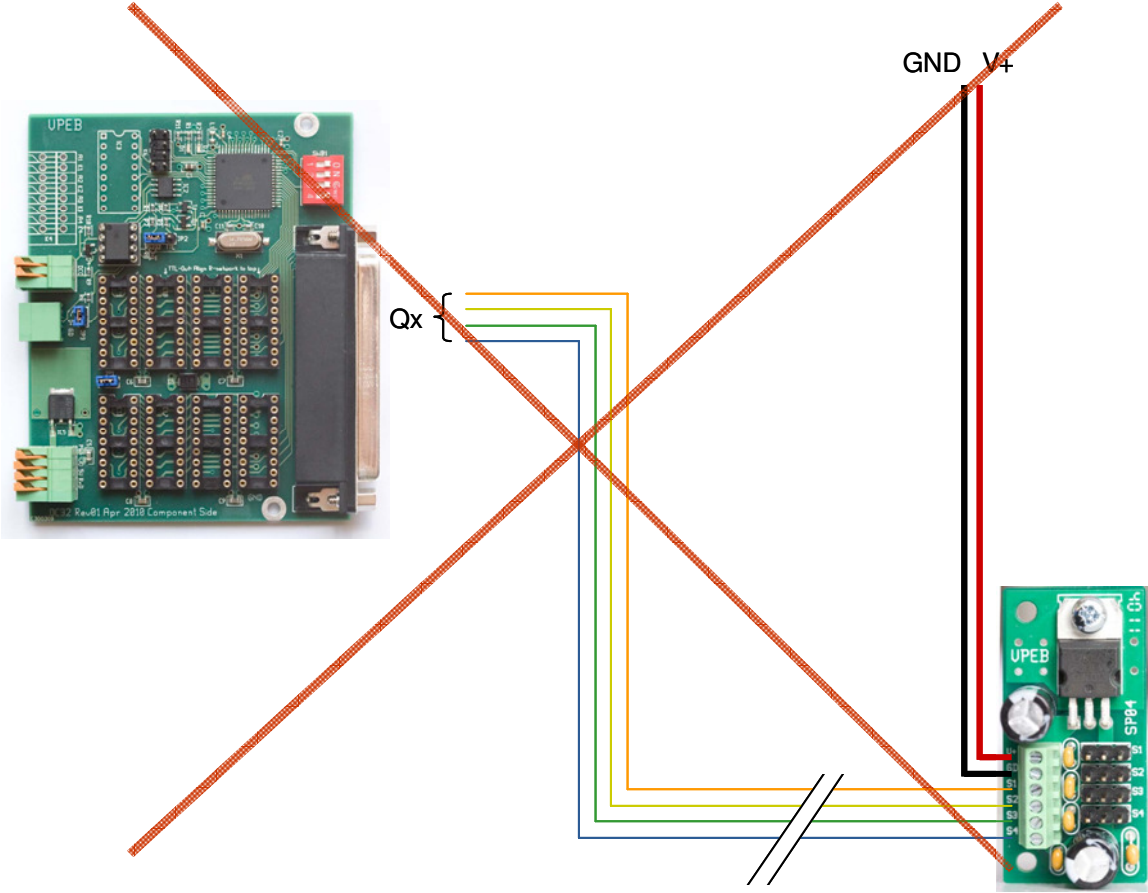

Fig 8: NOT this way!

4 To conclude

Additional information, software and updates can be found at the VPEB website: www.vpeb.nl and in de Dinamo users group: www.dinamousers.net

If questions arise related to this manual or the application of the SP04, try to find an answer via the Dinamo users group. If necessary there is a DinamoUsers portal with a forum you can use.

When you have questions about an order or other more personal matters feel free to send an e-mail to dinamo@vanperlo.net